

TAC Xenta[®] 527-NPR

For TAC I/NET

The TAC Xenta 527-NPR is a cost-effective and feature-enhanced version of the I/NET Net Plus Router. The TAC Xenta 527-NPR carries out many of the functions of a host PC but at a controller level, which reduces any dependence on host computers. The NPR deals with peer-to-peer point interaction, and manages and buffers events as necessary. All stored events and transactions are fully protected against loss of power by onboard batteries. The Xenta 527-NPR only supports connections to I/NET networks. It does not support LonWorks, or any other protocols.

This version of the Xenta 527-NPR introduces the ability to create segmented IP networks within an I/NET architecture. Encryption is available at the Ethernet level for high security applications. Configuration is performed using I/NET, a serial terminal, or pre-defined web pages. The Xenta 527-NPR does not require and is not supported by TAC XBuilder.

PERFORMANCE

I/NET Network

The TAC Xenta 527-NPR has the capability to act as a Net Plus Router within that system. The TAC Xenta 527-NPR has been tested to deliver up to a maximum of 15 I/NET alarms/events/transactions per second or 1.3 million per day. The

maximum burst can be up to 40 per second for 8 seconds.

The thruput for a single TAC Xenta 527-NPR is determined by the amount of polling the device is managing. Polling is created mainly by

- Points on open graphics pages
- The scan rate of connection objects

- The volume of alarm and event traffic
- The physical size of the connected I/NET system is a factor in this but is not a primary limitation.

In some systems therefore more than one TAC Xenta 527-NPR may be required to handle the total system traffic.

TECHNICAL DATA

Supply voltage 24 V AC \pm 20%, 50/60 Hz or 19–40 V DC
 Power consumption max. 5 W
 Transformer sizing 5 VA

Ambient Temperature

Storage -20°C to $+50^{\circ}\text{C}$ (-4°F to $+122^{\circ}\text{F}$)
 Operation $\pm 0^{\circ}\text{C}$ to $+50^{\circ}\text{C}$ ($+32^{\circ}\text{F}$ to $+122^{\circ}\text{F}$)
 Humidity max. 90% RH non-condensing

Mechanical

Enclosure ABS/PC
 Enclosure rating IP 20
 Flammability class, materials UL 94 V-0
 Dimensions see Fig. 1
 Weight 0.2 kg (0.44 lb.)

Real Time Clock

Accuracy at $+25^{\circ}\text{C}$ ± 12 minutes per year
 Power failure protection72 h

Communication

A: RS232 2400 – 57600 bps, RJ45, 8-p
 A: RS485 2400 – 57600 bps, async. terminal block
 B: RS232RJ10, 4-p
 C: RS485 sync. (SDLC) terminal block
 LonWorks TP/FT-10, terminal block
 Ethernet TCP/IP, 10Base-T, RJ45

Agency Compliances

Emission:
 CE EN 61000-6-3
 Immunity:
 CE EN 61000-6-2
 Safety:
 CE EN 61010-1
 UL 916 C-UL US Listed

Part Numbers

TAC Xenta 527-NPR 0-073-0821
 Terminal part TAC Xenta 400 0-073-0902
 TAC Xenta: Programming Serial Kit 0-073-0920

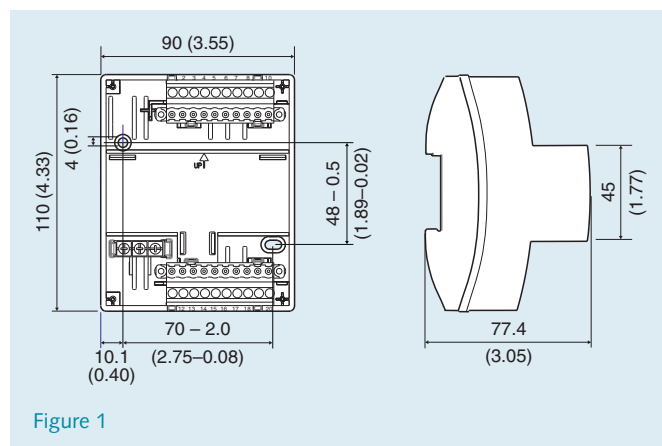

Figure 1

WEB INTERFACE

TAC Xenta 527-NPR uses a web interface to configure network, time, servers and ports among others.

CABLES

G and G0: Min. cross-sectional area 0.75 mm² (AWG-19).

C1 and C2: TAC Xenta 527 web server communicates on a joint network, LonWorks TP/FT-10, 78 kbps.

SECURITY

TAC Xenta 527-NPR uses a secure interface for configuration with username and password logon.

The TAC Xenta 527-NPR supports configurable I/P level encryption and I/P level filtering when being used in a security network.

DESIGN AND MOUNTING

The TAC Xenta 527-NPR is designed around a microprocessor. The device consists of two parts, a terminal including the terminal block, and the electronics with the circuit boards and contacts (fig. 2).

Power Outage Protection

Settings, like configuration and web pages, are stored in the non-volatile (flash) memory and will not be lost after a power outage.

Real Time Clock

The clock provides the internal event log with a time stamp. A built-in capacitor maintains operation of the clock for at least 72 hours in the event of a power failure. This real time clock can be configured to synchronize with the TAC I/NET host and automatically adjust for day light saving changes.

Mounting

The TAC Xenta 527-NPR is cabinet mounted on a TS 35 mm norm rail EN 50022.

To simplify installation, the terminal can be pre-mounted in the cabinet, (fig. 2). If the TAC Xenta 527-NPR is to be wall mounted, a wide range of standardized boxes are available.

INSTALLATION/CONNECTION

Modular Jacks

- RS232 A: Modem connection. Connection using hardware signals for modem communication.
- RS232 B: PC ("Console") connection. Connection using basic signals, primarily intended for a PC during configuration.
- 10Base-T: Connection for a LAN (Ethernet) cable and commissioning.

MMC

Connection for a MultiMedia Card (extra memory card). Not required for TAC Xenta 527-NPR.

Terminal Connections

Term.	Term. No.	Description Name
1	G	24 V AC (or DC+)
2	G0	Ground
3	C1	LonWorks TP/FT-10
4	C2	LonWorks TP/FT-10
5	RX/TX+	RS485 A
6	RX/TX-	RS485 A
7	RX+	RS485 A
8	RX-	RS485 A
9	G0	
10	Fail-safe	
-		
-		
19	RX/TX+	RS485 C (SDLC)
20	RX/TX-	RS485 C (SDLC)

CONFIGURING

The TAC Xenta 527-NPR is configured using a combination of specialized web pages, a serial terminal, and I/NET Seven clients.

SNMP

TAC Xenta 527-NPR can communicate using Simple Network Management Protocol (SNMP) which allows the exchange of management information between network devices. It is part of the TCP/IP protocol suite.

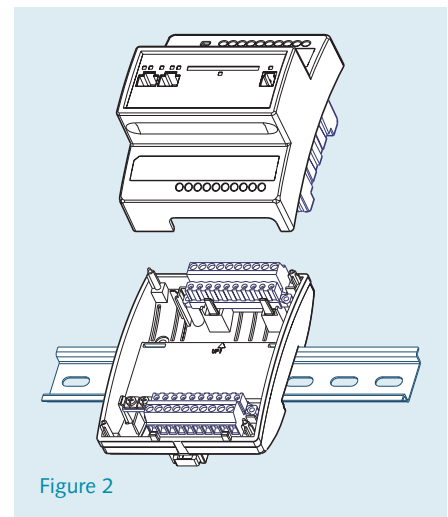

Figure 2

ACCESSORIES

Serial Communication

For installing the TAC Xenta 527-NPR, cable kit 0-073-0920 is needed, ordered separately.

Modem Connection

For connecting the TAC Xenta 527-NPR, cable kit 0-073-0916 is needed, ordered separately.

Cable

The TAC Xenta 527-NPR is connected to the Ethernet network with a standard UTP-cable or a standard STP-cable. For more information, see TAC Xenta 511/527/911/913, Handbook.

DOCUMENTATION

- Engineering TAC Xenta Server – TAC Xenta 511/527 (004-7845)
- Engineering TAC Xenta Server – TAC Xenta 527/527-NPR Supplement (004-7682)
- Operating TAC Xenta 527 (004-7683)
- Installation Instructions (OFL-3956)
- TAC Xenta 511/527/911/913 – Handbook (004-7870)