



TAC Xenta 701/721

Controller

The TAC Xenta 701/721 are multifunctional control systems with an embedded web server that allows you to access your control application and configuration pages via a web browser anywhere in the world, anytime.

The TAC Xenta 701 and 721 can run multiple concurrent control applications at various speeds. The control applications are created with the easy to use TAC Menta programming tool by connecting functional blocks in a graphical environment. Each application can be viewed on-line over the Internet. Furthermore, as Xenta Servers they can be connected via TCP/IP to TAC Vista in larger installations where they can aggregate data for easy operation and benchmarking.

Up to 1000 Xenta 701s and/or Xenta 721s can be connected to a TAC Vista Server.

The Xenta 701 supports up to 10 Xenta 400 I/O modules and the Xenta 721 supports up to 20 Xenta 400 I/O modules and 30 Xenta 280/300/401 modules.

The TAC Xenta 701/721 can also communicate with Modbus devices.

TECHNICAL DATA

Supply voltage 24 V AC $\pm 20\%$, 50/60 Hz or 19–40 V DC
 Power consumption max. 5 W
 Transformer sizing 5 VA

Ambient Temperature

Storage $-20\text{ }^{\circ}\text{C}$ to $+50\text{ }^{\circ}\text{C}$ ($-4\text{ }^{\circ}\text{F}$ to $+122\text{ }^{\circ}\text{F}$)
 Operation $\pm 0\text{ }^{\circ}\text{C}$ to $+50\text{ }^{\circ}\text{C}$ ($+32\text{ }^{\circ}\text{F}$ to $+122\text{ }^{\circ}\text{F}$)
 Humidity max. 90% RH non-condensing

Mechanical

Enclosure ABS/PC
 Enclosure rating IP 20
 Flammability class, materials UL 94 V-0
 Dimensions see Figure 1
 Weight 0.2 kg (0.44 lb.)

Real Time Clock

Accuracy at $+25\text{ }^{\circ}\text{C}$ ± 12 minutes per year
 Power failure protection 72 h

Communication

A: RS232 2400–57600 bps, RJ45, 8-p
 A: RS485 2400–57600 bps, async. terminal block
 B: RS232 RJ10, 4-p
 C: RS485 sync. (SDLC) terminal block
 LonWorks TP/FT-10, terminal block
 Ethernet TCP/IP, 10Base-T, RJ45

Agency Compliances

Emission: CE EN 61000-6-3
 C-tick C-Tick N1831
 FCC FCC Part 15, Subpart B, Class B
 Immunity:
 CE EN 61000-6-2

Safety:

CE EN 61010-1
 UL 916 C-UL US Listed
 RoHS directive 2002/95/EG

Part Numbers

Electronics part TAC Xenta 701 007301500
 Electronics part TAC Xenta 721 007301600
 Terminal part TAC Xenta 400 007309020
 TAC Xenta: PC to Serial Kit 007309170
 TAC Xenta: Serial Link Kit 007309180
 TAC Xenta: General Serial Kit 007309190
 TAC Xenta: Programming Serial Kit 007309200

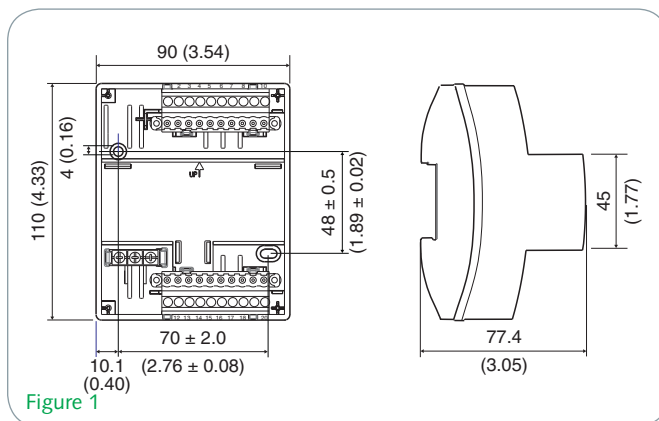

Figure 1

WEB PRESENTATION

The web pages based on HTML in the Xenta 701/721 are used for configuration. The programming tool, TAC XBuilder, is used for designing, generating and maintaining the controller.

TAC XBuilder is also used for defining and configuring the network variables used for trend logs, alarm objects and event logging.

Application Program Viewer

A graphic representation of the application code is displayed in the application program viewer (fig. 2). Function blocks and signals are displayed, these including a dynamic indication of their state or value as the execution proceeds. Static parts, such as texts and comments are also displayed.

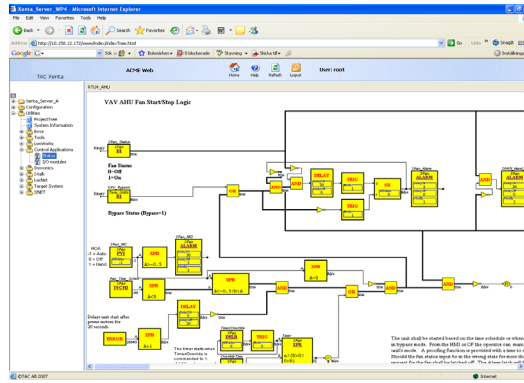

Figure 2

CONTROL APPLICATION

The control applications in the Xenta 701/721 are created by using the programming tools TAC XBuilder and TAC Menta in combination.

The powerful high performance application engine in the Xenta 701/721 can handle a large number of concurrent control applications with different cycle times.

Demanding applications such as lighting control can be handled thanks to the availability of short cycle times (100 ms (fig 3).

The engineering of a control application is easy and efficient as it uses multiple instances of an application (fig. 4).

The re-use of existing Menta applications, made for Xenta 280/ 300/401, is supported by importing and converting them to fit the Xenta 701/721.

The online debugging of the control application over the Internet is easily accomplished using the easily accessible function block diagrams for all Menta applications in the Xenta 701/721.

An application can be downloaded to the Xenta 701/721 without interfering with the other applications. Restarting the device is not necessary.

The complete range of Xenta 400 I/O modules are supported and configured in TAC XBuilder (fig. 5).

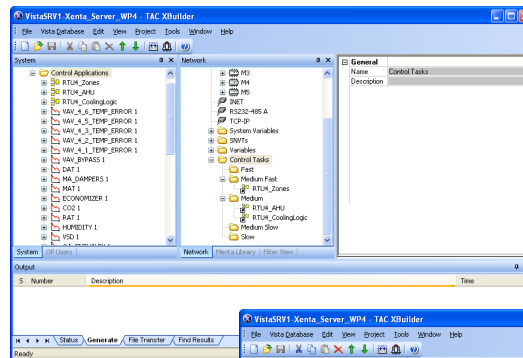

Figure 3

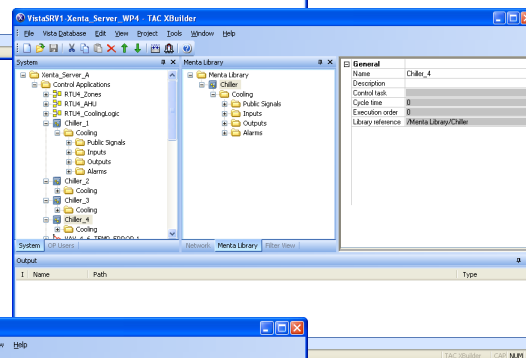

Figure 4

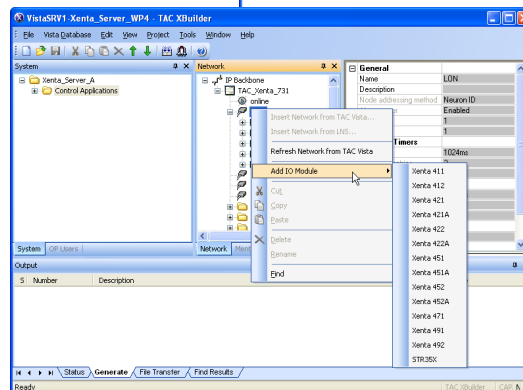

Figure 5

OPERATOR PANEL OP7

OP7 is connected to Xenta 701/721 by use of the OP7 Power adapter. The content of OP7 is created in XBuilder, either automatically or manually configured. A user with the sufficient access rights can use OP7 to

- Monitor and modify values
- View and modify schedules
- View and acknowledge alarms
- View trend logs

SYSTEM ARCHITECTURE

The web presentation of events and status from the controller and LonWorks network is reached through Ethernet or the RS232 A port (fig. 6).

The Xenta 701/721 is one of the nodes in the LonWorks network. A binding tool, for example LonMaker, can be used for installing the Xenta 701/721 in the network. When using TAC Vista no binding tool is needed.

Xenta 701/721 communicates via SNVT or TAC proprietary protocol with the rest of the LonWorks nodes.

A modem can be connected to the Xenta 701/721 using the RS232/RS485 A port.

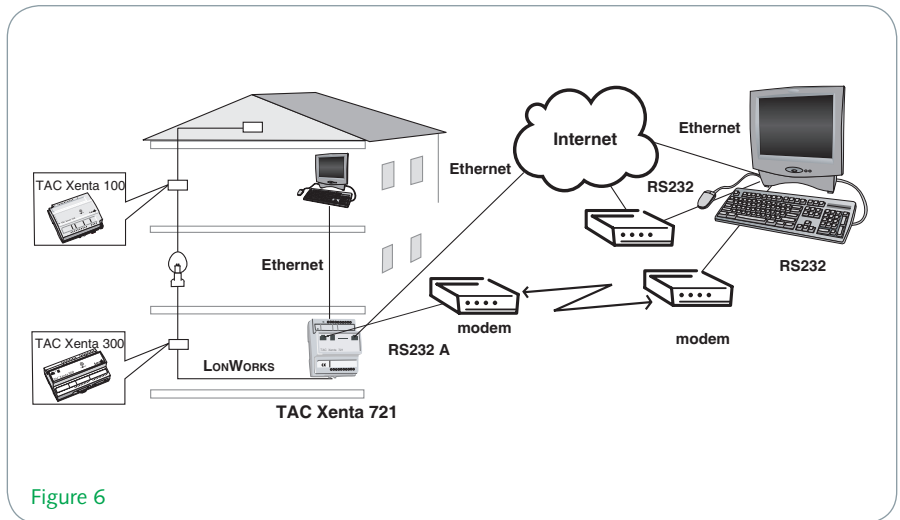

Figure 6

SERVER FUNCTIONS

Web Server

The web server in the Xenta 701/721 is used for configuration only and supports HTTP version 1.0.

Trend Log

The capacity for trend logging objects is a maximum of 300 objects for each Xenta 701/721. Up to 200,000 values can be logged.

Alarm Handling

The Xenta 701/721 can supervise 300 internal alarm objects and, at the same time, 1,400 alarm objects from the LonWorks network.

The signals can be both digital and analog.

Time Schedules

The Xenta 701/721 can handle 50 time objects with 50 week and 50 holiday schedules in each.

Modem

The serial channel port RS232 A in Xenta 701/721 supports modem signals.

Xenta 701/721 has both dial-up and dial-in capability and alarms can be sent as e-mail.

Xenta 701/721 supports PAP and CHAP authentication.

File Server

An FTP (File Transfer Protocol) server in the Xenta 701/721 makes file transfer possible.

Time Synchronization

The Xenta 701/721 internal time can be synchronized with an external Time Server using NTP (Network Time Protocol) or with another Xenta 701/721, using SNTP (Simple NTP).

Moreover, the Xenta 721 can synchronize the time in local LonWorks networks with Xenta 280/30x/4xx units.

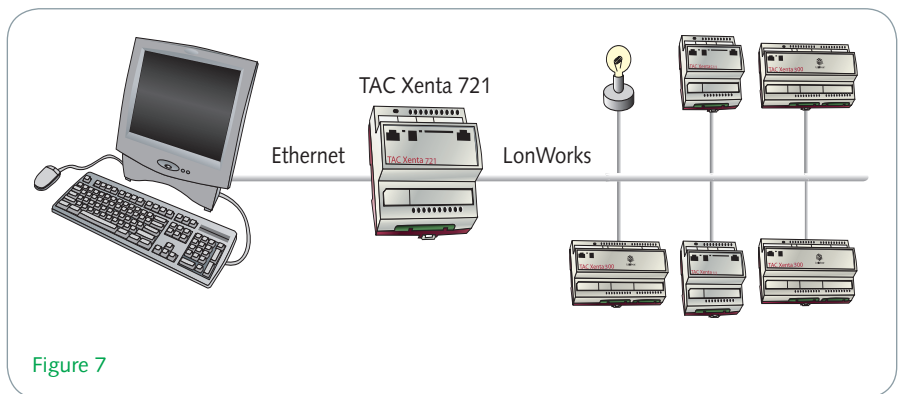

Figure 7

Security

The Xenta 701/721 is provided with mechanisms to guarantee a high level of security.

The unit is protected against both unauthorized access and incorrect operation.

User accounts and access rights can be administered via the web interface.

The security mechanism is based on HTTPS and the use of 128 bit encryption keys. This level of security is considered to be very high and is used by many international banks and e-commerce sites.

The Xenta 701/721 uses a secure interface for configuration with user name and password logon.

The Xenta 701/721 supports configurable I/P level encryption and I/P level filtering when being used in a security network.

SNMP

The Xenta 701/721 can communicate using Simple Network Management Protocol (SNMP) which allows the exchange of management information between network devices. It is part of the TCP/IP protocol suite.

CLIENT COMPUTER

Web Browser

Xenta 701/721 is optimized for Microsoft Internet Explorer version 6.0 or later.

Java Virtual Machine

Support for Java applets might not be available in all web browsers. If so, a Java plug-in must be installed, otherwise the web pages based on Java applets can not be used.

Java plug-ins for download are found at Sun Microsystems site for Java technology at

<http://java.sun.com>.

PC Hardware Requirements

Internal memory min. 128 MB, 512 MB recommended.

LONWORKS NETWORK

The Xenta 701/721 has the capacity to supervise a LonWorks network with approximately 30 nodes. The amount of SNVTs possible to bind to each unit is about 400. Both polled and bound SNVTs can be monitored.

ACCESSORIES

Serial Communication

For installing the Xenta 701/721, cable kit 007309200 is needed, ordered separately.

Modem Connection

For connecting the Xenta 701/721, cable kit 007309160 is needed, ordered separately.

Cable

The Xenta 701/721 is connected to the Ethernet network with a standard UTP-cable or a standard STP-cable. For more information see TAC Xenta 500/700/555/911/913, Handbook.

CABLES

- G and G0: Min. cross-sectional area 0.75 mm² (AWG-19).
- C1 and C2: Xenta 701/721 communicates on a joint network, LonWorks TP/FT-10, 78 kbps.

OP7

Operator panel for Xenta 701/721 See the OP7 data sheet (03-00072) for details.

DESIGN AND MOUNTING

The Xenta 701/721 is designed around a microprocessor.

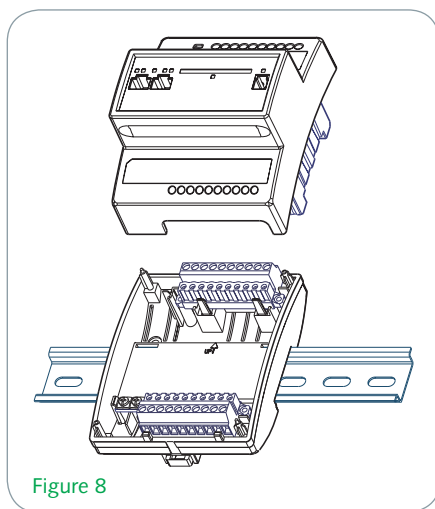

Figure 8

The device consists of two parts, a terminal including the terminal block, and the electronics with the circuit boards and contacts (fig. 8).

Power Failure Protection

Settings, like configuration and web pages, are stored in the non-volatile (flash) memory and will not be lost after a power outage.

Real Time Clock

The clock provides the internal event log with a time stamp. A built-in capacitor maintains operation of the clock for at least 72 hours in the event of a power failure. This real time clock can be configured to synchronize with the TAC Vista Server and automatically adjust for day light saving changes.

Mounting

The Xenta 701/721 is cabinet mounted on a TS 35 mm norm rail EN 50022.

To simplify installation, the terminal can be pre-mounted in the cabinet, (fig. 10).

If the Xenta 701/721 is to be wall mounted, a wide range of standardized boxes are available.

INSTALLATION/CONNECTION

Modular jacks

- RS232 A: Modem connection.
- RS232 B: PC ("Console") connection. Connection using basic signals, primarily intended for a PC during configuration.
- 10Base-T: Connection for a LAN (Ethernet) cable and commissioning.

LEDs

A number of light-emitting diodes in the electronics part of the Xenta 701/721 indicate that the application program is running and when communication is in progress.

"Reset Button"

Shorting terminals 9 and 10 ("Fail-safe") at restart will inhibit programs from hanging and put the internal program in a fail-safe state.

Terminal Connections

There is a label on the front of the module showing both the numbers and the names of the terminals (1 G, 2 G0 and so on). The numbers are also shown in the plastic of the terminal part.

Term.	Term. No.	Description Name
1	G	24 V AC (or DC+)
2	G0	Ground
3	C1	LonWorks TP/FT-10
4	C2	LonWorks TP/FT-10
5	RX/TX+	RS485 A
6	RX/TX-	RS485 A
7	RX+	RS485 A
8	RX-	RS485 A
9	G0	
10	Fail-safe	
16	G0	Ground
17	G0	Ground
19	RX/TX+	RS485 C
20	RX/TX-	RS485 C

Terminals 5-8 and 19-20 are currently not used.

AVAILABLE NETWORKS

LonWorks

The Xenta 701/721 is a web based controller for LonWorks networks.

The Xenta 701/721 can also act as a Xenta server for Lonworks and has built-in connectivity to Vista. This option provides an unsurpassed and integrated solution for building management and security. The Xenta 701/721 uses HTTPS, which is regarded as one of the most secure protocols on the Internet.

The Xenta 701 has all the features of the Xenta 721 apart from Xenta 280/300/400 support.

MODBUS COMMUNICATION

The TAC Xenta 701/721 can communicate with Modbus devices using:

- Serial interface (RS485 or RS232), as a Master with a maximum of 31 Slaves connected; or as a Slave.
- Modbus TCP through the 10Base-T port, as a Modbus TCP client. A maximum of 100 Modbus TCP Servers can be connected.

Port configuration is done in TAC Xbuilder.

Device Editor

The Device Editor, which is included in the TAC Xbuilder installation, is used to define the data exchange with connected devices. Reusable device templates are created for the device types.